

# Flygt 8053.280

---

# Table of Contents

<b>1 Introduction.....</b>	<b>2</b>
1.1 Specially approved products.....	2
<b>2 Product Description.....</b>	<b>3</b>
2.1 The data plate.....	3
2.2 Product denomination.....	3
<b>3 Exploded View.....</b>	<b>5</b>
3.1 Drive Unit.....	5
3.1.1 Standard.....	5
3.1.2 Cable entries.....	6
3.2 Hydraulic Unit.....	7
3.2.1 LT/MT/HT.....	7
3.3 Installation Components.....	8
3.3.1 Sliding brackets.....	8
3.3.2 Discharge connection units.....	9
<b>4 List of Parts.....</b>	<b>10</b>
4.1 8053.280.....	10

# 1 Introduction

## Purpose of this manual

The purpose of this manual is to provide necessary information on spare parts and accessories order.

## Disclaimer

Always use genuine Flygt parts. The use of other spare parts or accessories can invalidate any claims for warranty or compensation. Xylem does not take any responsibility for damages that are caused by the use of non-original parts. For more information, contact your local sales and service representative.

## Data for ordering spare parts

The following information is needed for spare part orders:

- Serial number of the product
- Part number
- Quantity of bulk material, see \* in tables

## 1.1 Specially approved products

### Qualification of personnel

Only Xylem or Xylem-authorized service personnel may undertake repair work on specially approved products.

### Dimensional accuracy inspection

Spare parts marked with (Ex) after the part number are subject to dimensional accuracy inspection when used in specially approved products.

# 2 Product Description

## 2.1 The data plate

The data plate is a metal label that is located on the main body of the products. The data plate lists key product specifications. Specially approved products also have an approval plate.

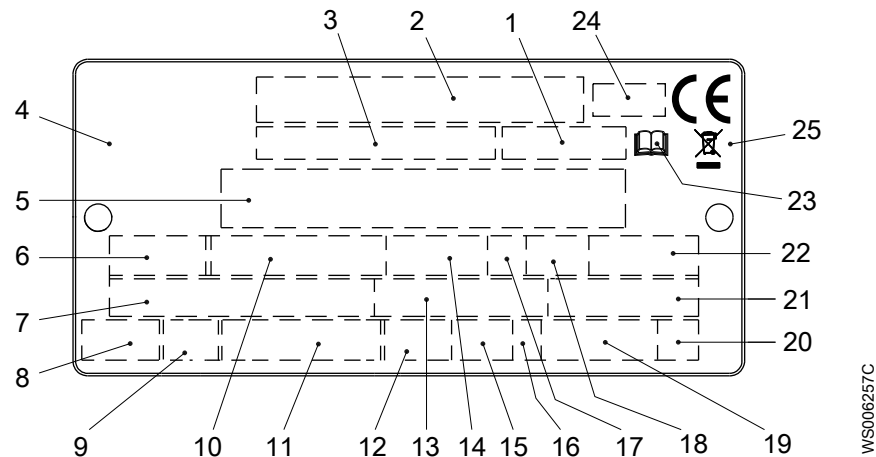

1. Curve code or Propeller code
2. Serial number
3. Product number
4. Country of origin
5. Additional information
6. Phase; type of current; frequency
7. Rated voltage
8. Thermal protection
9. Thermal class
10. Rated shaft power
11. International standard
12. Degree of protection
13. Rated current
14. Rated speed
15. Maximum submergence
16. Direction of rotation: L=left, R=right
17. Duty class
18. Duty factor
19. Product weight
20. Locked rotor code letter
21. Power factor
22. Maximum ambient temperature
23. Read installation manual
24. Notified body, only for EN-approved Ex products
25. WEEE-Directive symbol

Figure 1: The data plate

## 2.2 Product denomination

### Reading instruction

In this section, code characters are illustrated accordingly:

X = letter

Y = digit

The different types of codes are marked up with a, b and c. Code parameters are marked up with numbers.

Codes and parameters

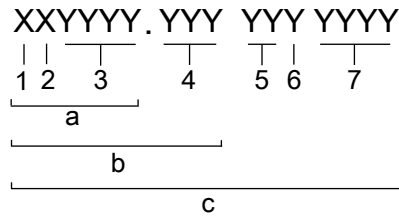

WS006265B

Type of Callout	Number	Indication
Type of code	a	Sales denomination
	b	Product code
	c	Serial number
Parameter	1	Hydraulic end
	2	Type of installation
	3	Sales code
	4	Version
	5	Production year
	6	Production cycle
	7	Running number

# 3 Exploded View

## 3.1 Drive Unit

### 3.1.1 Standard

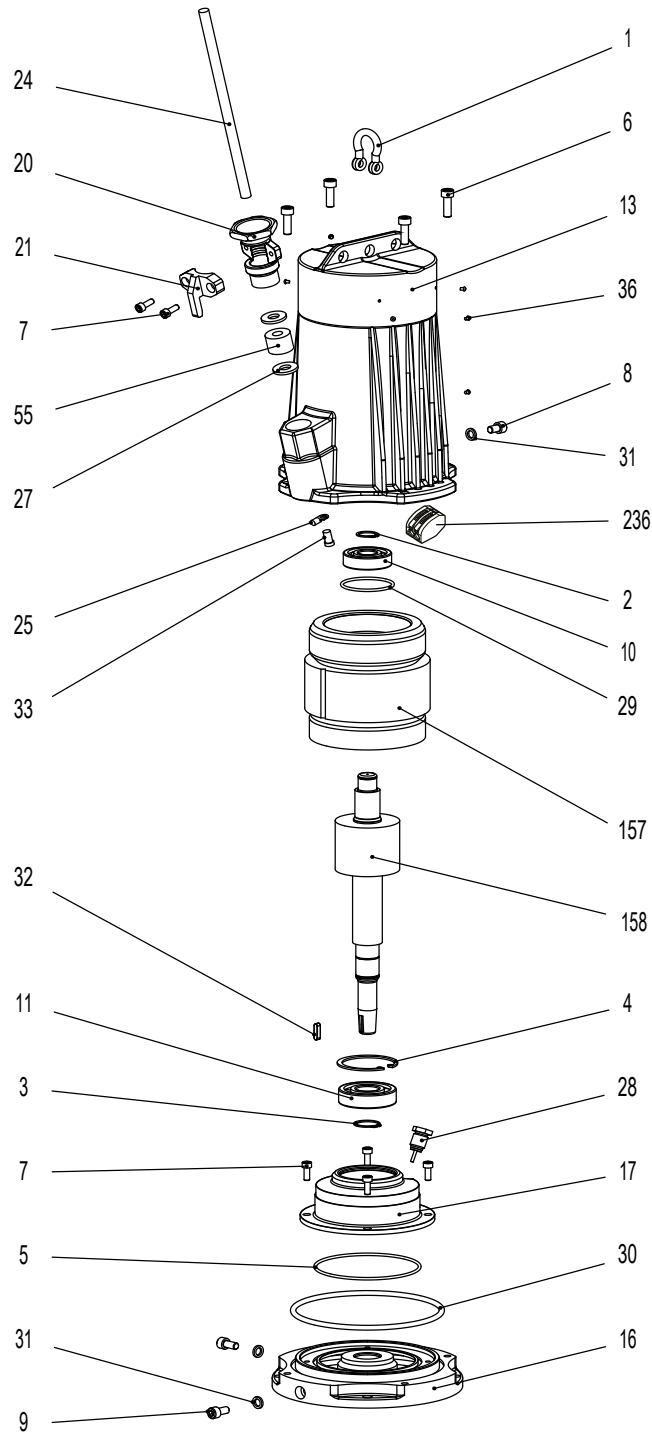

31508C

### 3.1.2 Cable entries

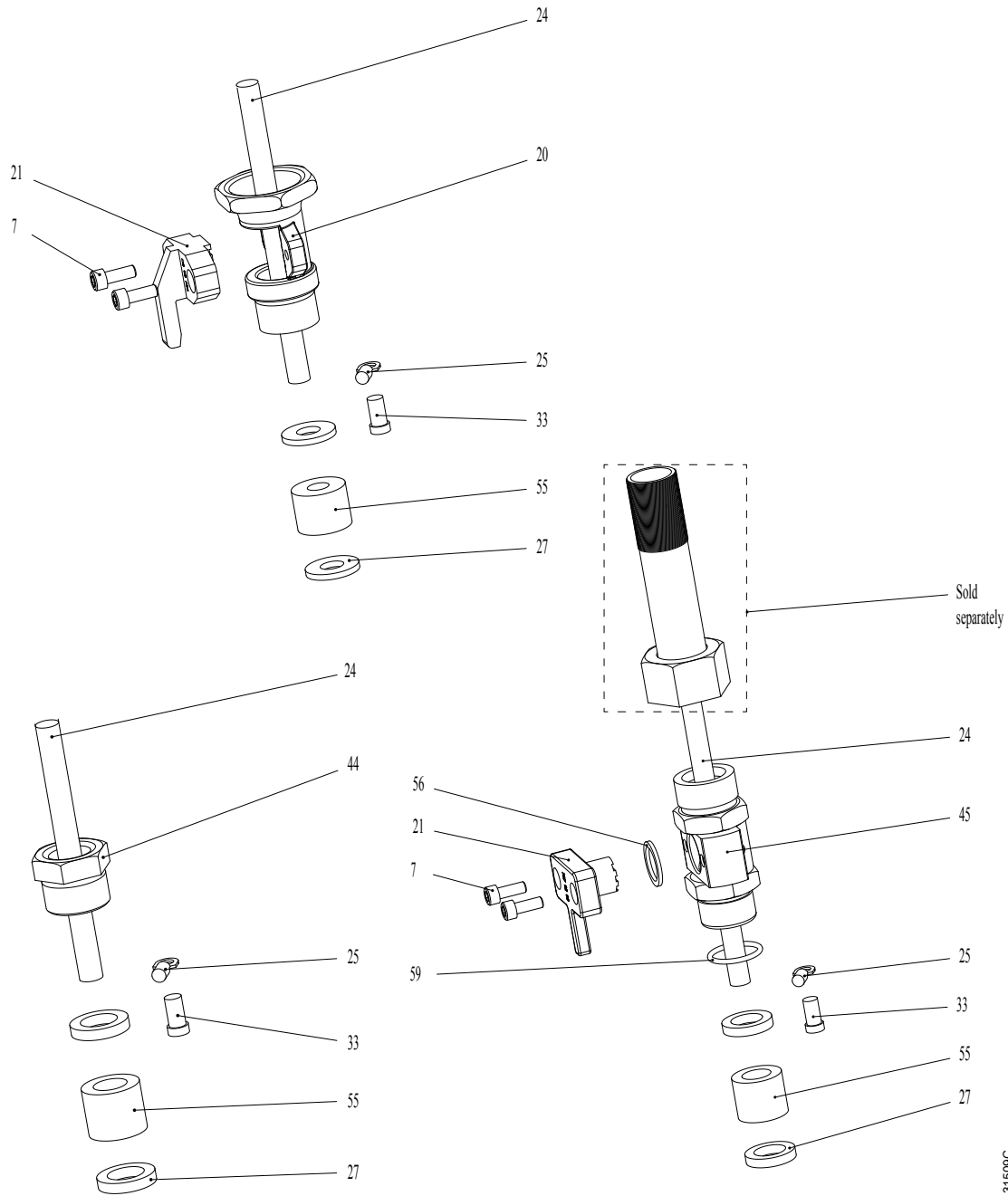

31509C

## 3.2 Hydraulic Unit

### 3.2.1 LT/MT/HT

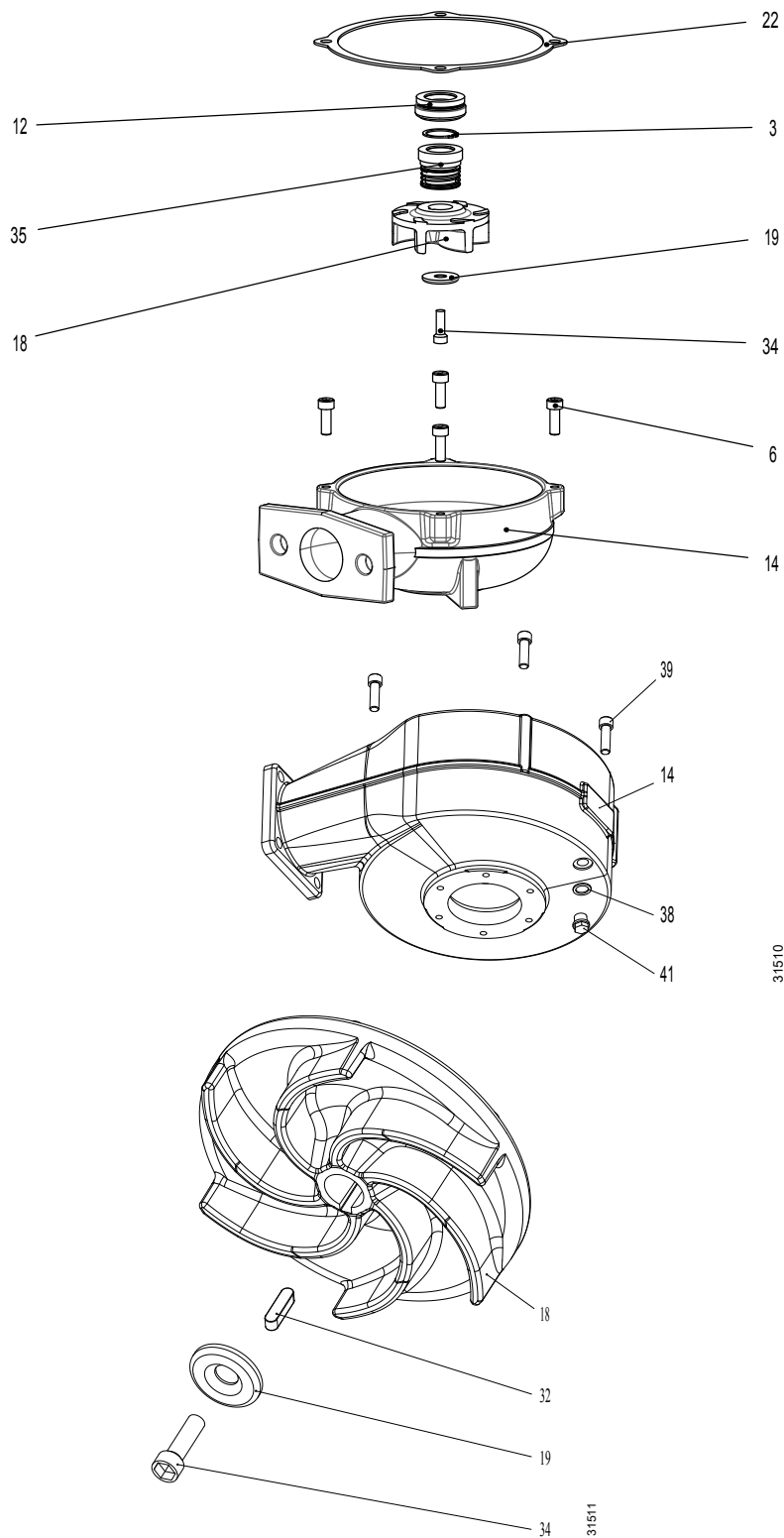



### 3.3 Installation Components

#### 3.3.1 Sliding brackets

LT

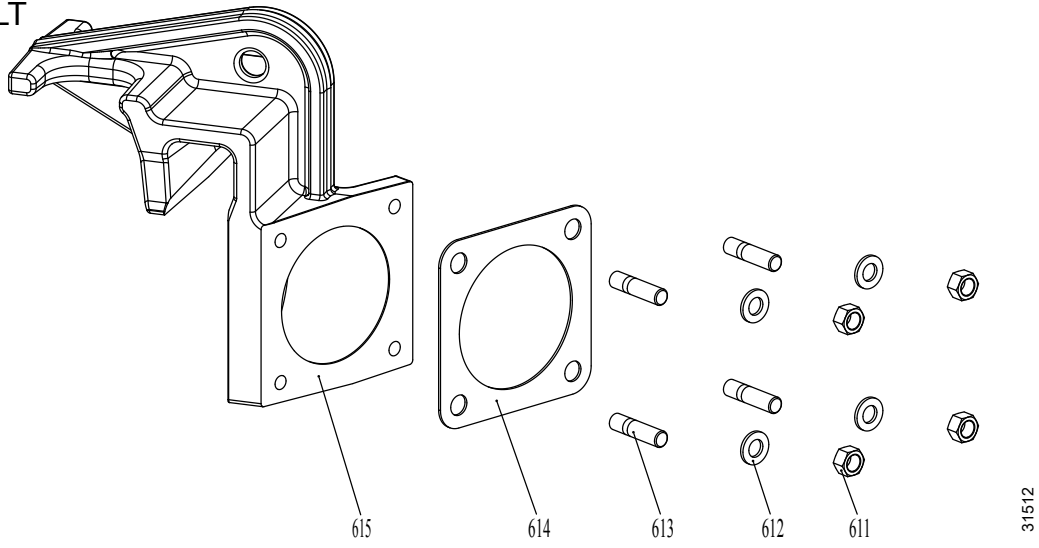

MT

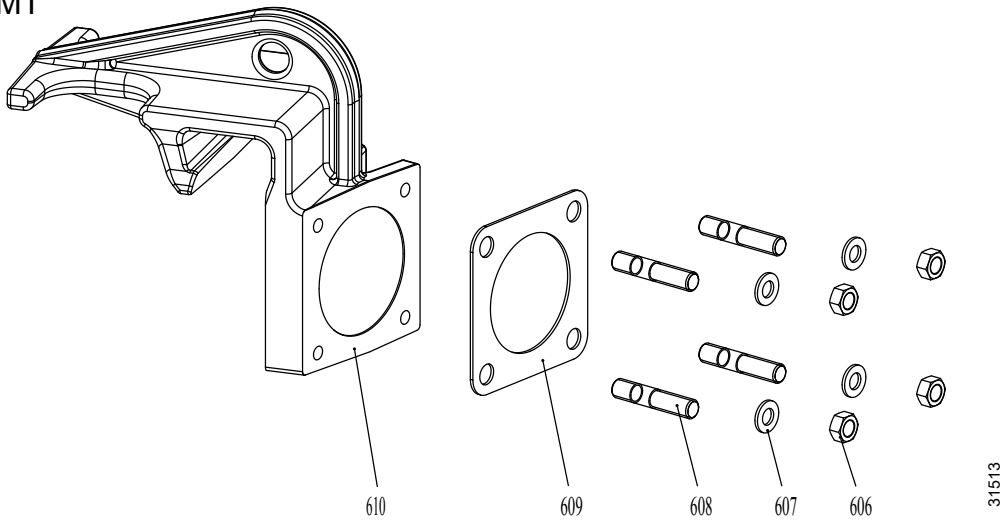

HT

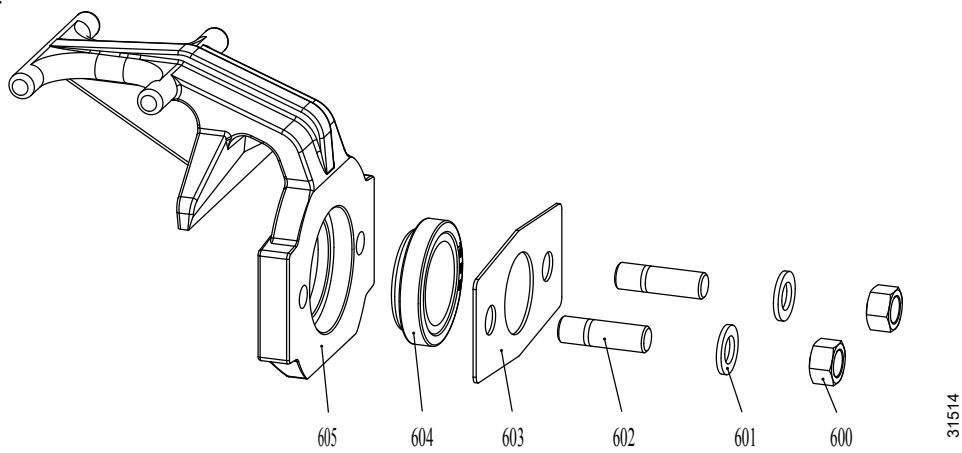

### 3.3.2 Discharge connection units

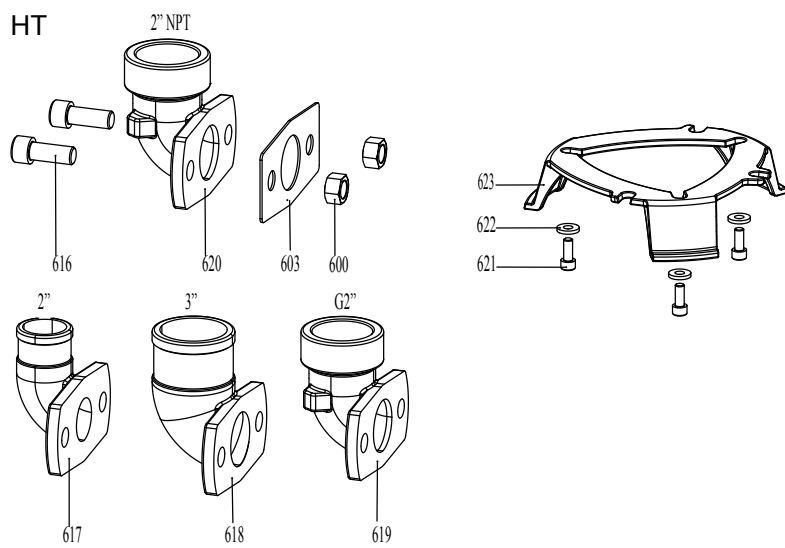
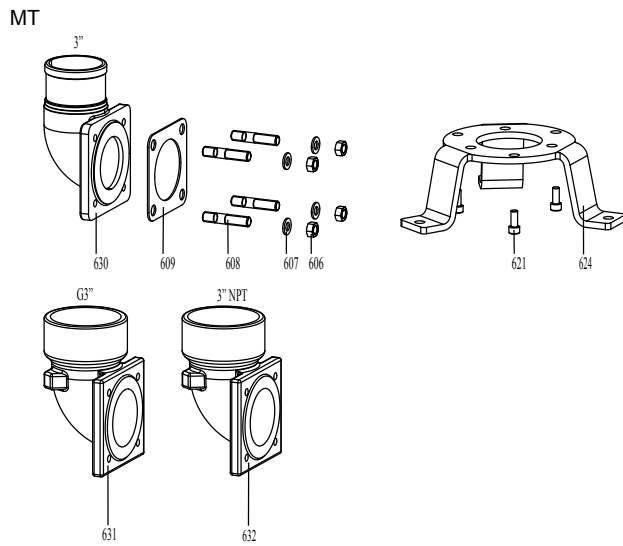
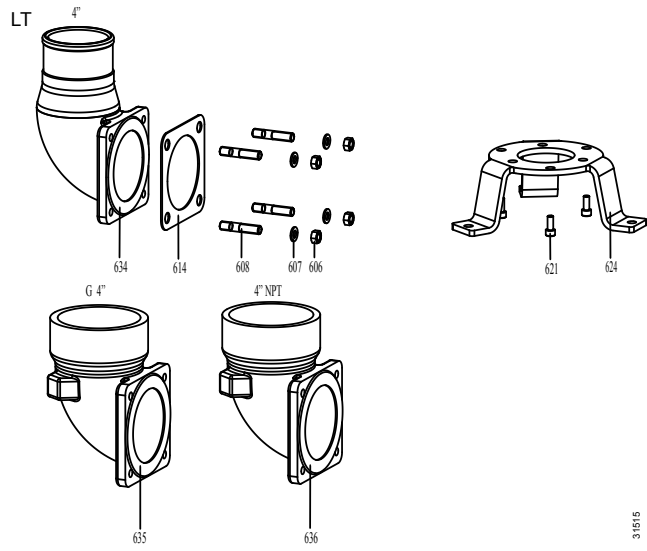

# 4 List of Parts

## 4.1 8053.280

Pos. No	Part. No	Type	Denomination	Qty/Version	
				280	
1	82 26 48		Shackle	1	
2	82 60 92		Retaining ring SGA 20	1	
3	82 61 32		Retaining ring SGA 25	2	
4	82 62 12		Retaining ring SGH 62	1	
5	82 81 67		O-ring 109.5X3 FPM	1	
6	83 02 01		Hex.socket hd screw M8X25-A4-80	4	
7	83 02 75		Hex.socket hd screw M6X16-A4-70	4	
7	83 02 75		Hex.socket hd screw M6X16-A4-70	2	
8	83 02 95		Hex.socket hd screw M8X12-A4-70	1	
9	83 02 97		Hex.socket hd screw M8X16-A4-70	2	
10	83 33 13		Ball bearing 20X52X15 MM	1	
11	83 33 14		Ball bearing 25X62X17	1	
12	83 76 74		Mechanical seal Al2O3/CARBON NBR	1	
13	736 95 00		Stator housing	1	
14	736 99 00		Pump housing	LT	1
14	737 00 00		Pump housing	MT	1
14	737 01 00		Pump housing	HT	1
16	737 29 00		Oil housing	LT	1
				MT	
16	737 28 00		Oil housing	HT	1
17	737 35 00		Bearing housing		1
17	737 35 02		Bearing housing WITH WATER DETECTOR		1
18	737 38 40		Impeller Ø210		1
18	737 38 42		Impeller Ø195		1
18	737 38 44		Impeller Ø185		1
18	737 38 46		Impeller Ø175		1
18	737 38 48		Impeller Ø165		1
18	737 44 00		Impeller Ø150		1
18	737 41 00		Impeller Ø138		1
18	737 41 01		Impeller Ø125		1
18	737 41 02		Impeller Ø118		1
19	737 47 00		Plain washer 10X30X4		1
20	737 85 00		Motor cable entry LONG		1
21	737 88 00		Cable clamp Ø12-14 MM		1
21	737 92 00		Cable clamp Ø15-17 MM		1
21	737 87 00		Cable clamp Ø18-23 MM		1
22	738 33 00		Gasket	LT	1
				MT	
22	738 32 00		Gasket	HT	1

Pos. No	Part. No	Type	Denomination	Qty/Version
				280
24	94 20 61		Motor cable subcab 4G1.5+2X1.5	*
24	94 20 82		Motor cable subcab 7G2.5+2X1.5	*
24	90 34 25		Motor cable H07RN-F 10G1,5	*
24	94 20 91		Motor cable hcr 7X2,5	*
24	94 20 59		Motor cable subcab 4G2.5+2X1.5	*
24	94 20 60		Motor cable subcab 4G4+2X1.5	*
25	81 79 30		Cable lug 2.5 - 6 MM2 M6	1
27	83 76 27		Plain washer 12X27.5X3-A4	2
27	83 76 24		Plain washer 17.5X27.5X4-A4	2
28	83 76 39		Level sensor	1
29	83 76 46		O-ring 152X3.53 FPM	1
30	83 76 44		O-ring 52.39X3.53 NBR	1
31	583 32 01		Seal ring HNBR	3
31	583 32 01		Seal ring HNBR	1
32	83 76 53		Parallel key	1
33	83 76 56		Slotted head screw M6X8	1
34	83 76 72		Hex socket hd screw M 8 X20-A4-50	1
35	83 76 75		Mechanical seal RSiC/RSiC FPM	1
36	82 21 73		Drive screw 4X5-A4	6
38	83 76 55		Seal washer	1
39	83 03 47		Hex.socket hd screw M12X35-A4-70	4
41	83 76 54		Plug DIN910 R3/8"-A4	1
44	737 89 00		Motor cable entry SHORT	1
45	737 91 00		Motor cable entry FOR CABLE PROTECTION	1
53	83 76 61		Flat pin sheet	1
55	83 76 26		Seal sleeve (10)-12 MM FPM	1
55	83 76 05		Seal sleeve (15)-17 MM CR	1
55	83 76 11		Seal sleeve (17)-20 MM CR	1
55	83 76 06		Seal sleeve (18)-21 MM CR	1
55	83 76 07		Seal sleeve (21)-23 MM CR	1
57	667 40 00		Sticker	2
58	340 71 00		Instruction plate	1
59	83 76 45		O-ring 25.07X2.62 FPM	1
60	630 68 00	(Ex)	Data plate USE 6306801 AS SPARE PART	2
71	737 93 00		Cable clamp Ø18-21 MM	1
96	90 17 52		Oil ISO VG 32	*
157	737 07 01		Stator 15-10-2r 50 Hz 2-poles 380V-415V D P2=4kW 60 Hz 2-poles 440V-480V D P2=4,60kW/6,20hp	1
157	737 07 02		Stator 15-10-2r 50 Hz 2-poles 220V-230V D P2=4kW	1

Pos. No	Part. No	Type	Denomination	Qty/Version
				280
157	737 07 03		Stator 15-10-2r 50 Hz 2-poles 500V-525V D P2=4kW 60 Hz 2-poles 575V D P2=4,60kW/ 6,20hp	1
157	737 07 04		Stator 15-10-2r 60 Hz 2-poles 440V-460V YSER 220V-230V Y// P2=4,60kW/6,20hp	1
157	737 07 05		Stator 15-10-2r 60 Hz 2-poles 380V D P2=4,60kW/ 6,20hp	1
157	737 07 06		Stator 15-10-2r 60 Hz 2-poles 220V D P2=4,60kW/ 6,20hp	1
157	737 06 01		Stator 15-10-4r 50 Hz 4-poles 380V-400V D 690V Y P2=3,50kW 60 Hz 4-poles 440V-460V D P2=4kW/5,40hp	1
157	737 06 02		Stator 15-10-4r 50 Hz 4-poles 220V-230V D P2=3,50kW	1
157	737 06 03		Stator 15-10-4r 50 Hz 4-poles 500V D P2=3,50kW 60 Hz 4-poles 575V D P2=4kW/ 5,40hp	1
157	737 06 05		Stator 15-10-4r 60 Hz 4-poles 380V D P2=4kW/ 5,40hp	1
157	737 06 06		Stator 15-10-4r 60 Hz 4-poles 220V D P2=4kW/ 5,40hp	1
157	737 06 07		Stator 15-10-4r 50 Hz 4-poles 415V D P2=3,50kW 60 Hz 4-poles 480V D P2=4kW/ 5,40hp	1
158	737 25 00		Shaft unit	1
158	737 26 00		Shaft unit	1
236	85 08 72		Terminal block	2
236	85 08 73		Terminal block	3
236	85 08 72		Terminal block	8
236	83 56 75		Shrinking terminal	6
236	85 08 72		Terminal block	1
600	82 23 37		Hexagon nut M16-A4-70	2
601	82 35 78		Plain washer 17X30X3-A4-170HV	2
602	80 97 59		Stud 16X35-A4-70	2
603	742 88 02		Gasket	1
604	738 38 00		Seal ring	1
605	737 59 00		Sliding bracket	1
606	82 23 33		Hexagon nut M10-A4-70	4
606	82 23 35		Hexagon nut M12-A4-70	4
607	82 35 76		Plain washer 10.5X20X2-A4-170HV	4
607	82 35 77		Plain washer 13X24X2.5-A4-170HV	4
608	83 76 49		Stud 10X30-A4-70	4
608	80 97 39		Stud 12X30-A4-70	4
609	738 36 00		Gasket	1
610	737 60 00		Sliding bracket	1
611	82 23 35		Hexagon nut M12-A4-70	4

Pos. No	Part. No	Type	Denomination	Qty/Version
				280
612	82 35 77		Plain washer 13X24X2.5-A4-170HV	4
613	80 97 40		Stud 12X35-A4-70	4
614	738 35 00		Gasket	1
615	737 61 00		Sliding bracket	1
616	83 03 70		Hex.socket hd screw M16X40-A4-70	2
617	737 78 00		Discharge connection 2"	1
618	737 79 00		Discharge connection 3"	1
619	737 81 00		Discharge connection 2" NPT	1
620	737 81 01		Discharge connection G2"	1
621	83 02 99		Hex.socket hd screw M8X20-A4-70	3
622	83 76 57		Plain washer 20X8.4X3-A4	3
623	737 77 00		Stand	1
624	753 46 00		Stand MT	1
624	753 45 00		Stand LT	1
630	737 80 00		Discharge connection 3"	1
631	737 84 00		Discharge connection 3" NPT	1
632	737 84 01		Discharge connection G3"	1
634	737 83 00		Discharge connection 4"	1
635	737 82 01		Discharge connection 4" NPT	1
636	737 82 00		Discharge connection G4"	1
800	83 87 36		O-ring kits	1
800	83 87 37		O-ring kits	1
900	756 39 00		Basic repair kit	1
900	756 40 00		Basic repair kit	1



**ООО «Бауманс Груп» - официальный партнер фирмы Flygt в России.**

**Тел: +7 495 121 49 50**

**Эл. почта: [info@baumgroup.ru](mailto:info@baumgroup.ru)**

**Сайт: [www.baumgroup.ru](http://www.baumgroup.ru)**